



DS060 Odyssey Air and Nitrogen Booster

Trust, It's What We Build

Trust Hycomp's Odyssey line of Oil-Free Air and Nitrogen boosters for your critical project needs. Designed to prevent contamination and losses of the gas stream, these units provide worry free operation and a 20+ year life expectancy.



100% Oil-Free Gas Stream

**ISO 8573-1 Compliance
Eliminates Risk to Product
and Equipment**

**Durable Cast Iron and
Steel Construction**

24 Hour Duty Cycle

**Simple Annual
Maintenance**

**24 Hour Live Tech
Support**

Made in the USA

The Compressor So Reliable, You'll Forget It's There

DS060 Odyssey Air and Gas Booster

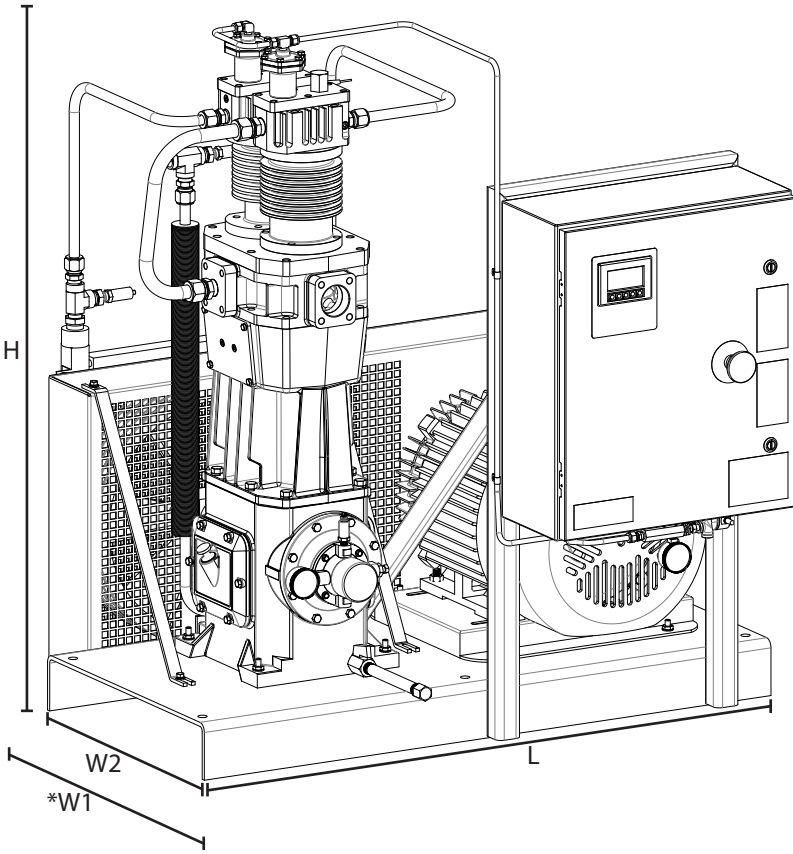

*Includes front control panel and rear belt guard assembly.

Capacity

Suction Pressure (PSIG)	Discharge Pressure (PSIG)	Minimum Flow (SCFH)	20 HP Maximum Flow (SCFH)	25 HP Maximum Flow (SCFH)
70	300	2,410	4,290	NA
70	400	2,330	3,940	4,140
70	450	2,290	3,760	4,080
70	500	2,250	3,490	4,000
80	300	2,740	4,860	NA
80	400	2,650	4,350	4,710
80	450	2,610	3,930	4,640
80	500	2,570	3,750	4,570
90	400	2,970	4,740	5,280
90	450	2,930	4,270	5,200
90	500	2,890	4,080	4,880
100	400	3,290	5,100	5,850
100	450	3,250	4,590	5,770

Table based on 80F suction temperature at sea level. Cooling fan option may be required to reach maximum flow. Contact Hycomp for specific capacity at given conditions. To ensure we are constantly improving, Hycomp reserves the right to make changes without prior notification.

Dimensions

Length:	52"
Overall Width (*W1):	46"
Skid Width (W2):	23"
Height:	54"
Estimated Weight:	1400 lbs
Estimated Shipping Weight:	1800 lbs
Suction (FNPT):	2"
Discharge (FNPT):	3/4"
Instrument Ports (FNPT):	1/4"

Technical Specifications

Bore:	4.00" x 2.50"
Stroke:	3.50"
No. of Stages:	2
No. of Cylinders:	2
Cooling:	Air
Controls:	PLC Touch Screen Interface
Compressor Model:	2AN15D

Utility Requirements

Power (20 HP):	460/3/60 27.3 FLA
Power (25 HP):	460/3/60 34.3 FLA

Additional Options

- Auxiliary Cooling Fan
- Cold Weather Packaging
- Duplex Programming
- Multiple Voltages
- Modbus Gateway
- Moisture Separators
- DSi Install Kit Includes:
 - Filters
 - Regulator
 - Tanks
 - Flex Hoses