



DS044 Odyssey Air and Nitrogen Booster

Trust, It's What We Build

Trust Hycomp's Odyssey line of Oil-Free Air and Nitrogen boosters for your critical project needs. Designed to prevent contamination and losses of the gas stream, these units provide worry free operation and a 20+ year life expectancy.



100% Oil-Free Gas Stream

**ISO 8573-1 Compliance
Eliminates Risk to Product
and Equipment**

**Durable Cast Iron and
Steel Construction**

24 Hour Duty Cycle

**Simple Annual
Maintenance**

**24 Hour Live Tech
Support**

Made in the USA

The Compressor So Reliable, You'll Forget It's There

DS044 Odyssey Air and Gas Booster

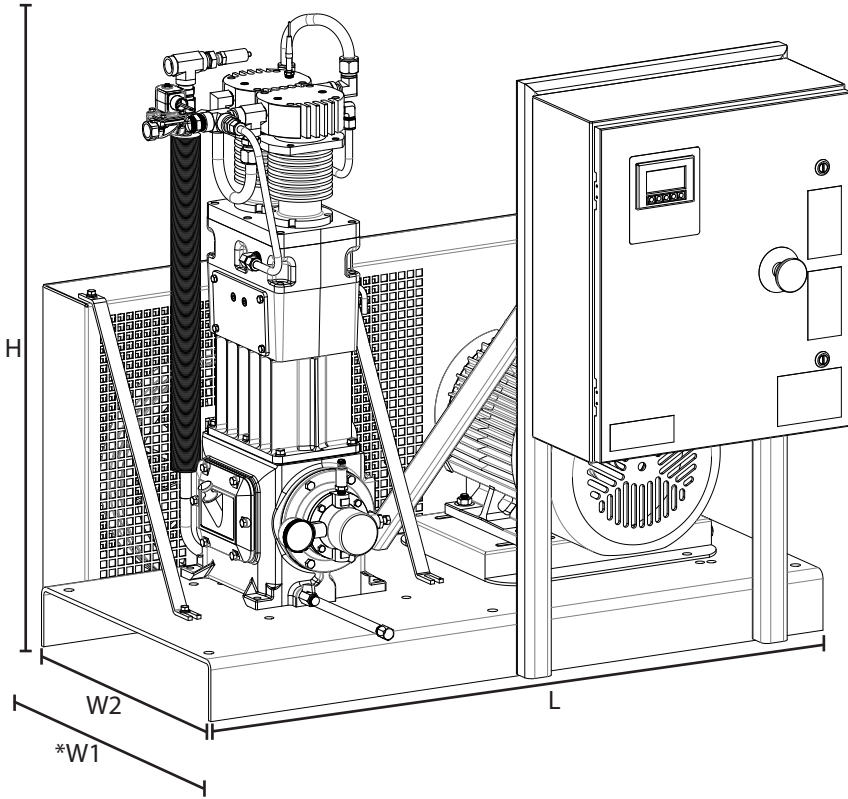

*Includes front control panel and rear belt guard assembly.

Dimensions

Length:	50"
Overall Width (*W1):	46"
Skid Width (W2):	23"
Height:	48"
Estimated Weight:	850 lbs
Estimated Shipping Weight:	1250 lbs
Suction (FNPT):	3/4"
Discharge (FNPT):	3/4"
Instrument Ports (FNPT):	1/4"

Technical Specifications

Bore:	2.50"
Stroke:	3.00"
No. of Stages:	1
No. of Cylinders:	2
Cooling:	Air
Controls:	PLC Touch Screen Interface
Compressor Model:	AN10C

Utility Requirements

Power (10 HP):	460/3/60 14.0 FLA
Power (15 HP):	460/3/60 21.7 FLA

Additional Options

- Auxiliary Cooling Fan
- Cold Weather Packaging
- Duplex Programming
- Multiple Voltages
- Modbus Gateway
- Moisture Separators
- DSi Install Kit Includes:
 - Filters
 - Regulator
 - Tanks
 - Flex Hoses

Capacity

Suction Pressure (PSIG)	Discharge Pressure (PSIG)	Minimum Flow (SCFH)	10 HP Maximum Flow (SCFH)	15 HP Maximum Flow (SCFH)
70	200	1,740	3,120	NA
70	250	1,660	2,700	2,980
70	300	1,590	1,860	NA
80	200	1,990	3,560	NA
80	250	1,910	3,000	3,420
80	300	1,840	2,560	2,980
90	200	2,240	4,010	NA
90	250	2,160	3,380	3,870
90	300	2,080	2,790	3,730
100	200	2,490	4,460	NA
100	250	2,410	3,910	4,310
100	300	2,330	3,120	4,170

Table based on 80F suction temperature at sea level. Cooling fan option may be required to reach maximum flow.

Contact Hycomp for specific capacity at given conditions.

To ensure we are constantly improving, Hycomp reserves the right to make changes without prior notification.

L250, Rev 3