

# Warranty Preventive Maintenance Schedule

For Boosters and Compressors

**THIS SCHEDULE MUST BE ADHERED TO AND DOCUMENTED DURING THE WARRANTY PERIOD FOR THE STANDARD HYCOMP WARRANTY TO BE VALID**

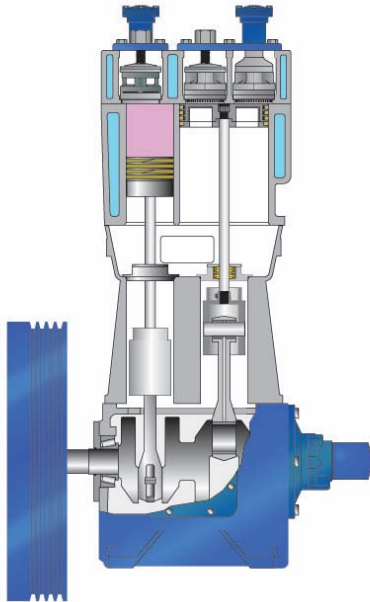

Air Compressor Cutaway

## Daily

- Visually Inspect Compressor
- Check Oil Pressure
- Check Discharge / Suction Pressures
- Drain Condensate from Piping System
- Drain Legs and Air Receiver

## Weekly

- Check for Oil in Distance Piece and Tube Drain
- Check for the Crankcase Oil Level
- Check for Air Leaks in Piping System

## Monthly

- Clean Cylinder, Intercooler, and Aftercooler Surfaces
- Check V-Belt Tension
- Inspect and Replace Filters as Required (See I&O Manual)

## Biannually

- Inspect Compression Valve Assemblies,  
Replace Springs/Discs as Required
- Inspect Unloader Diaphragms / Pistons

## Annually

- Change Oil and Oil Filter
- Inspect Motor Starter Contacts
- Lubricate Motor Bearings
- Replace PLC Battery
- Inspect Rings, Valves, Packings, and Oil Scrapers,  
Replace as Required

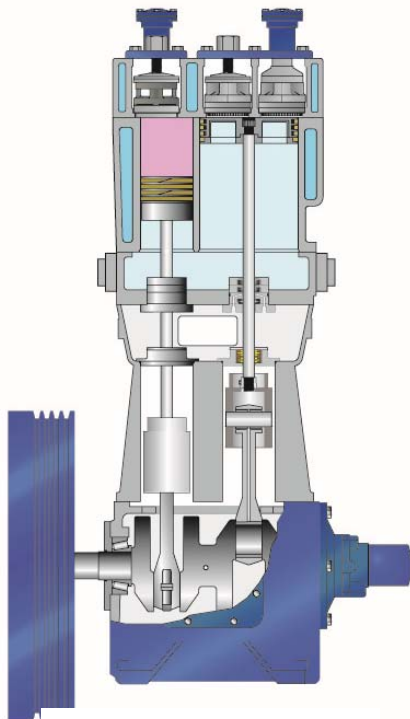

Booster Cutaway

The above schedule is designed for 8 hour a day operation compressing clean dry air at a ratio of 3.0 or less per stage. For gases other than air, or for "bone-dry" or saturated air, this schedule may need to be adjusted. Contact the factory for assistance in setting up a PM schedule to fit your specific application.